

# ASSEMBLY INSTRUCTIONS

## CHANGING STATION

Approximate Assembly Time



People Required to Assembly



Tools Required

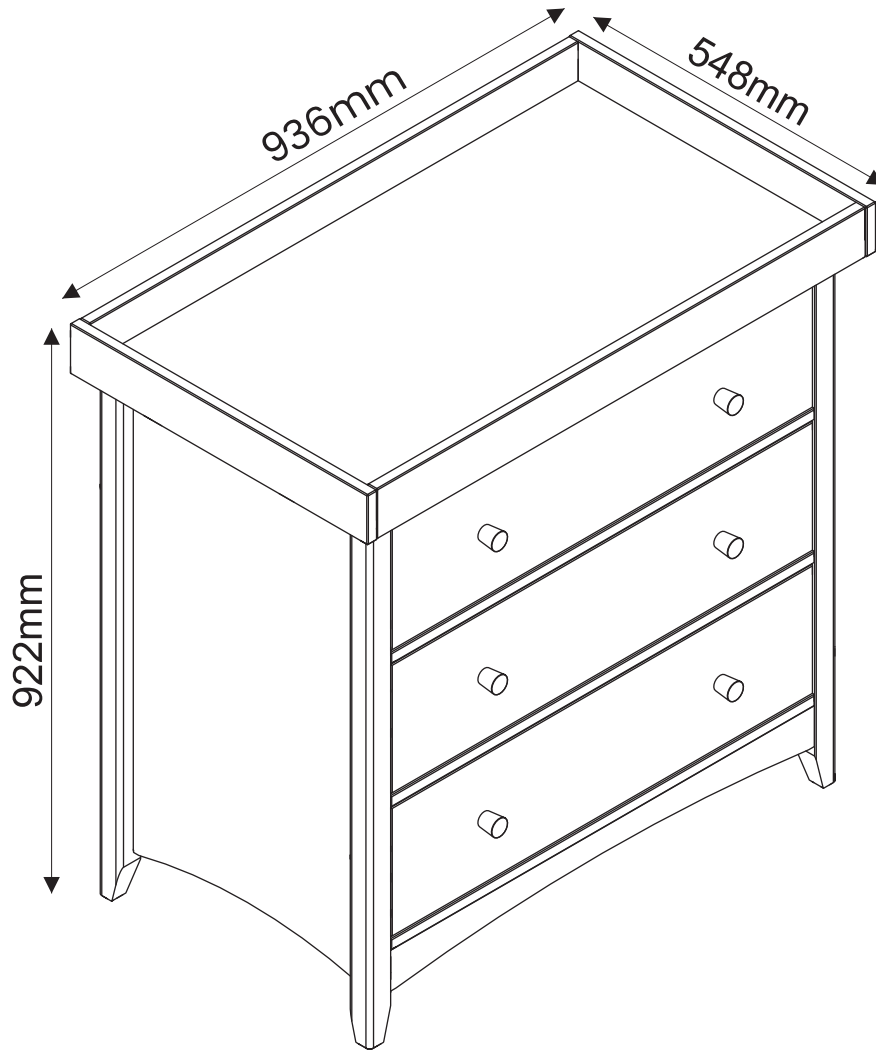
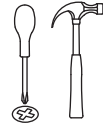

### Before you start...

Please carefully unpack and lay out all of the component parts to ensure nothing is missing and to check each component for any obvious damage.

Should you identify any concerns at this stage please contact the retailer from whom this product was purchased. Please quote your order number, details of your issue, the product code, and the batch number from the cartons which will help to resolve your issue as quickly as possible.

Version Number - 1.0

Product Code - CAM021

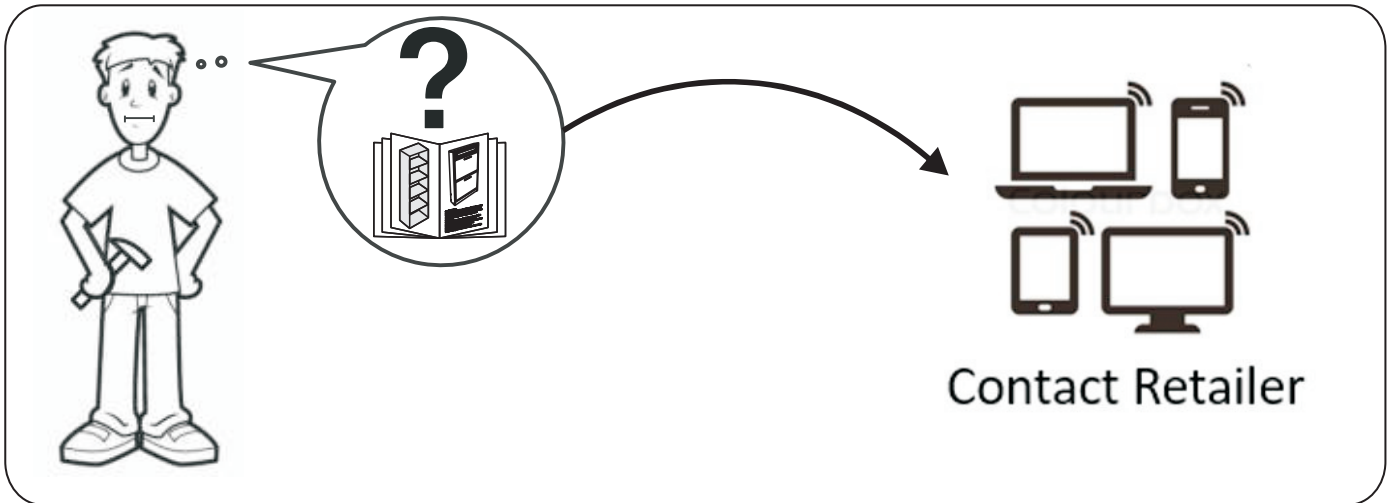
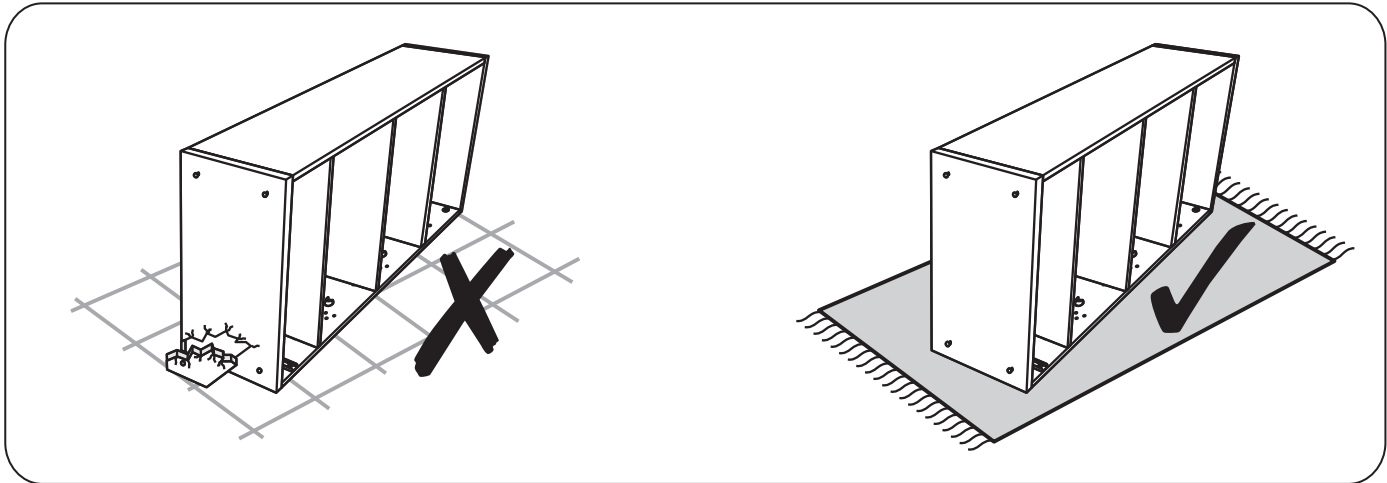
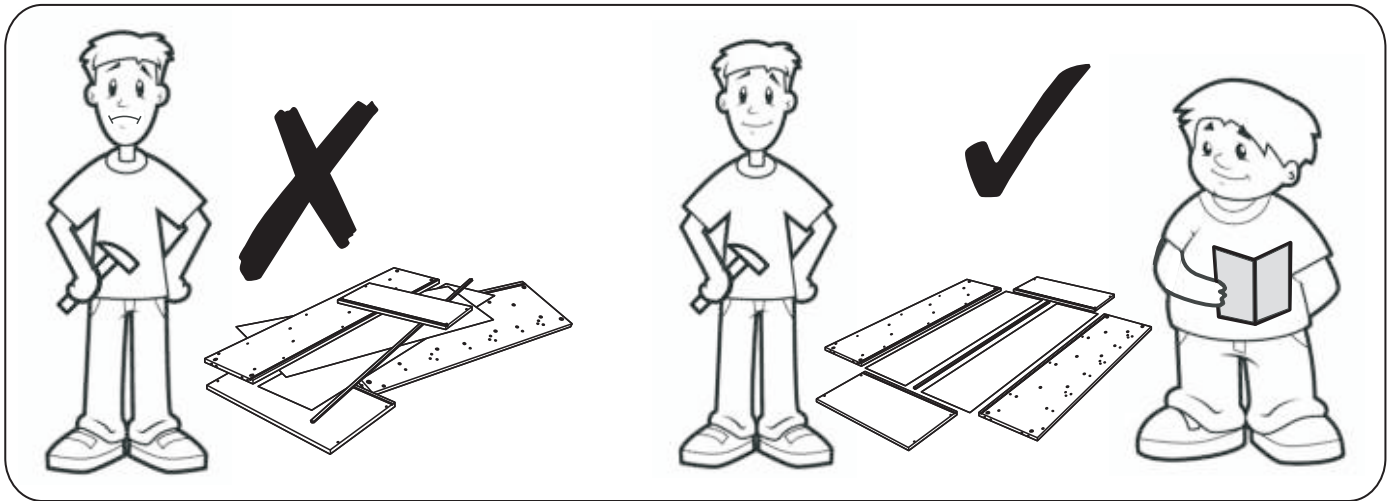
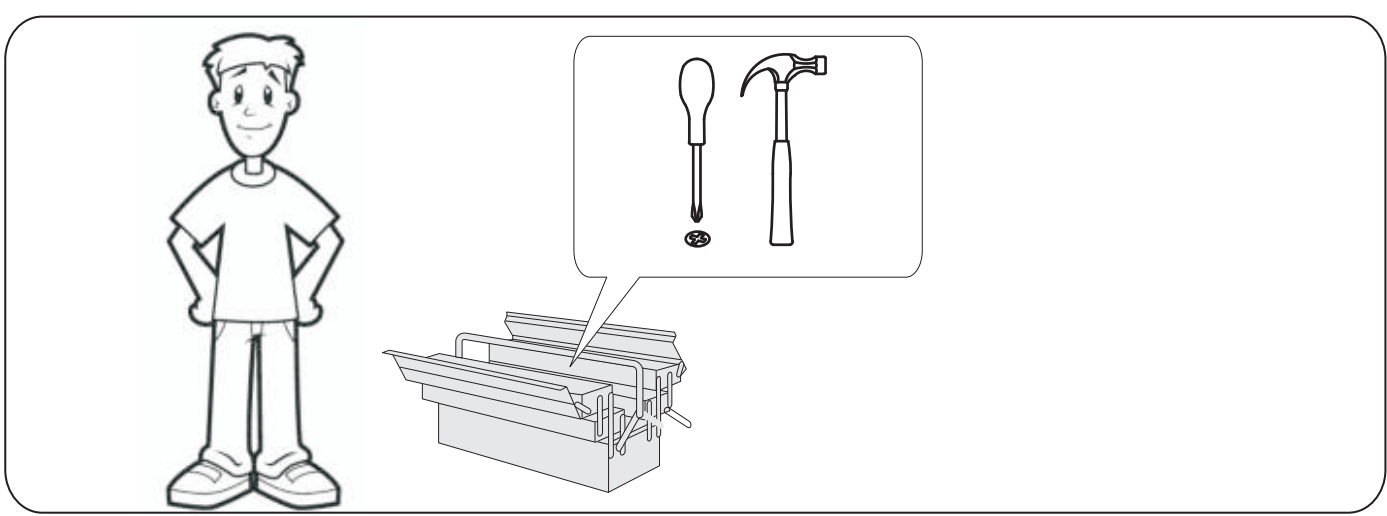

Please check all hardware matches the list below. Should you notice any are missing please contact your retailer.

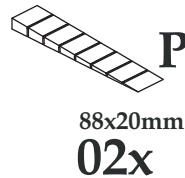
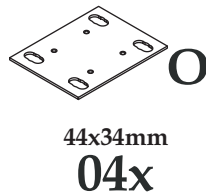
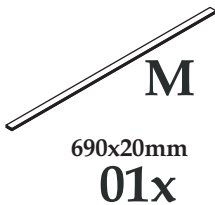
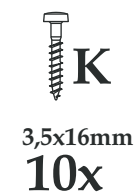
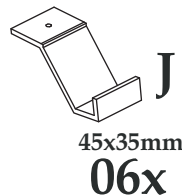
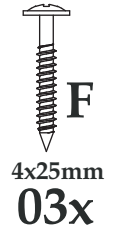

We strongly advise that you do not use Power Tools, such as drills or electric screwdrivers during the assembly as this may cause irreparable damage and will invalidate your warranty.



# PARTS

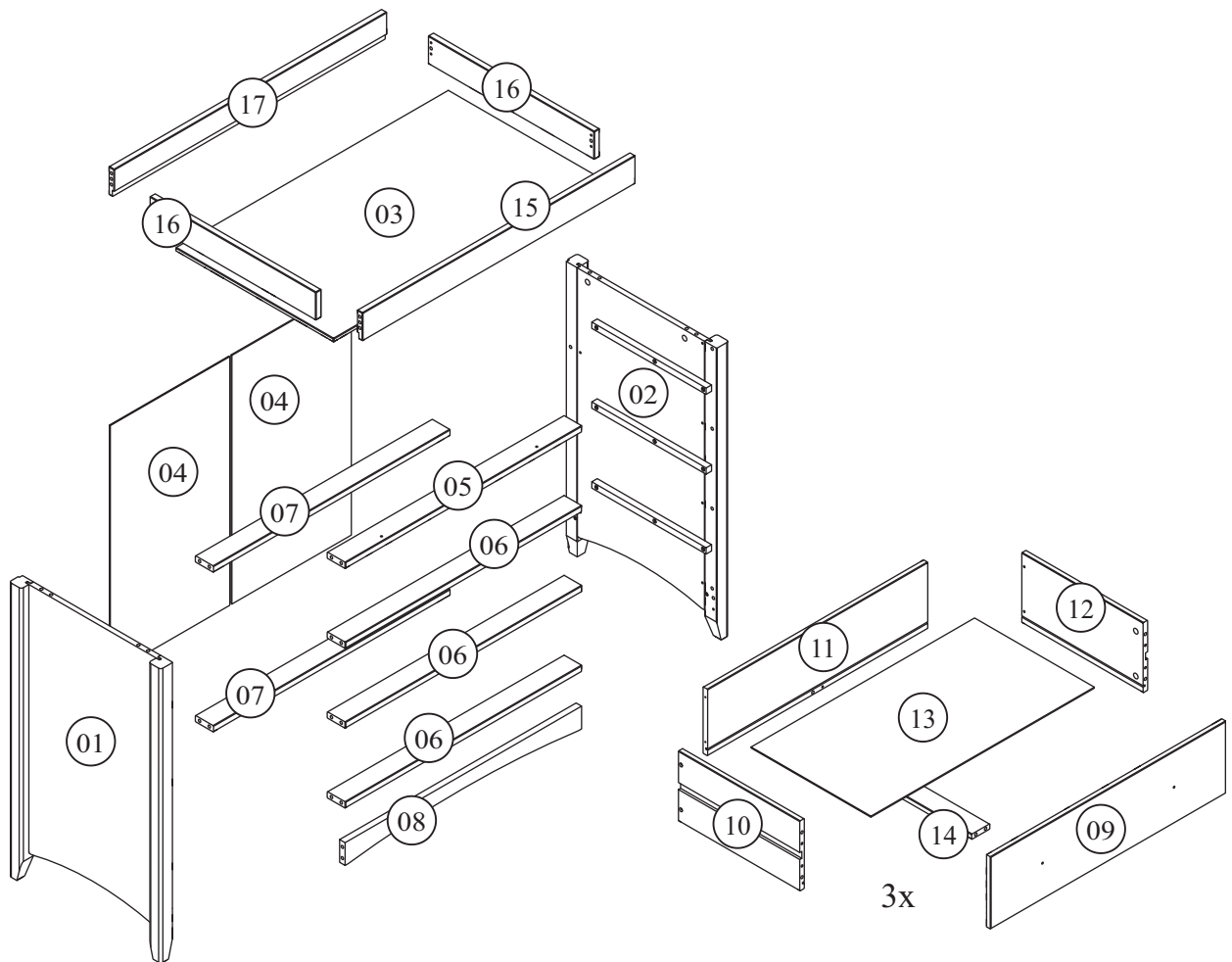

3x

Please ensure you carefully check all the pieces, should you have any concerns please contact the retailer before assembly commences. Please have your order number, details of the issue, the product code, and the batch number from the cartons as this will help us to resolve your issue much faster.

# **Safety Information**

**IMPORTANT, RETAIN FOR FUTURE REFERENCE: READ CAREFULLY**

**WARNING!** To prevent your furniture tipping and causing serious or fatal injuries, ensure this product is permanently fixed to the wall and the correct fitting type is used. The fitting included with this product is intended for securing the safety device to the product. If in doubt seek professional advice.

**WARNING!** Do not leave your child unattended.

**WARNING!** Do not move the changer with a child on it.

**WARNING!** Be aware of the risk of open fire and other sources of strong heat, such as electric bar fires, gas fires, etc, in the vicinity of the product.

**WARNING!** Do not use the product if any part is broken, damaged torn or missing, approved replacement parts can be obtained from Julian Bowen Limited.

An older child climbing on the changing unit while a child is on the changing surface is extremely dangerous and must be discouraged.

Keep away from trailing cords, drapes or flexes, and away from electric sockets.

All assembly fittings should be tightened properly, checked regularly and re-tightened as necessary.

The product must be used on a level and stable surface.

When lockable castors / wheels are fitted, ensure they are locked when the changing unit is in use.

A changing mat should always be used. Recommended size is 75cm x 46cm approximately.

Once assembled do not dismantle.

Suitable for a child up to 12 months or a maximum weight of 11 kg.

This product conforms to BS EN 12221-1:2008 + A1:2013.

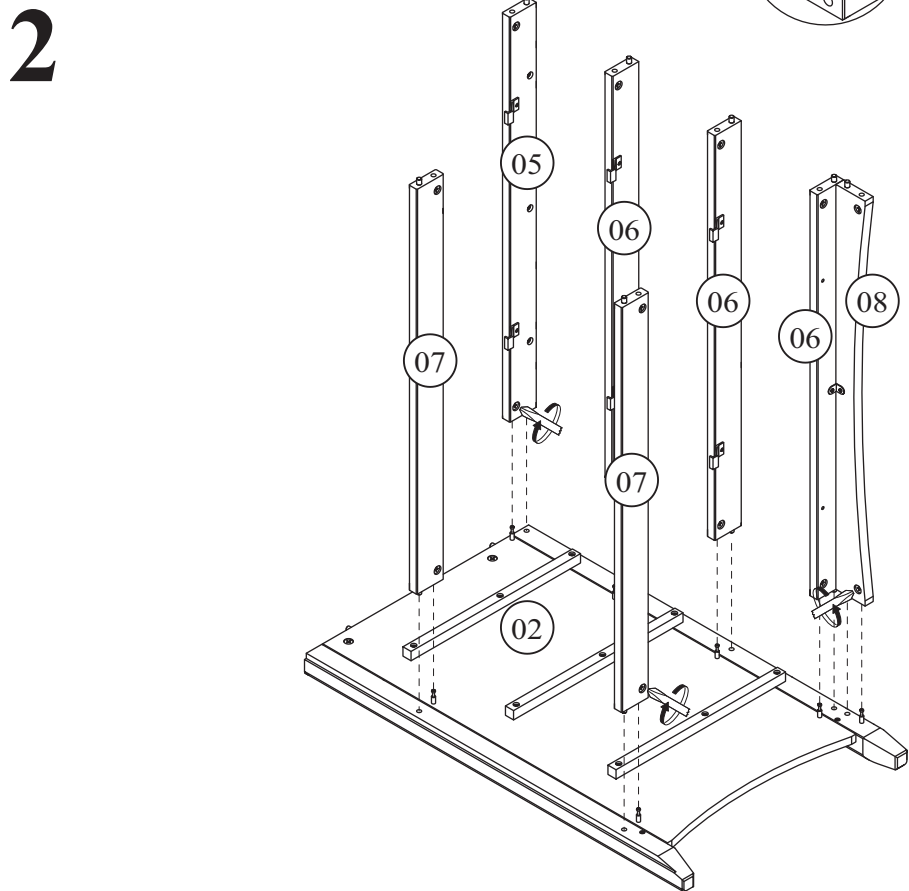
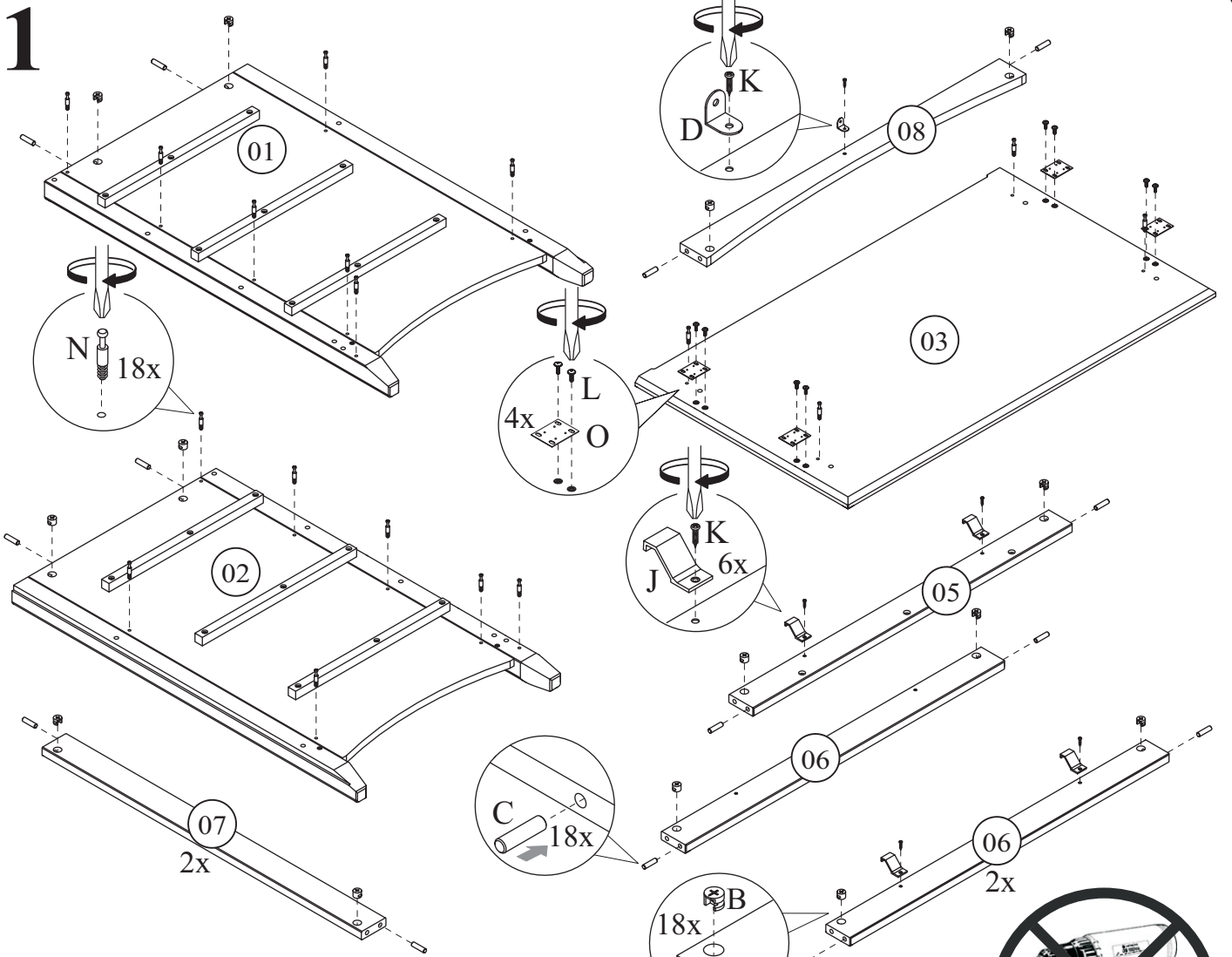

3

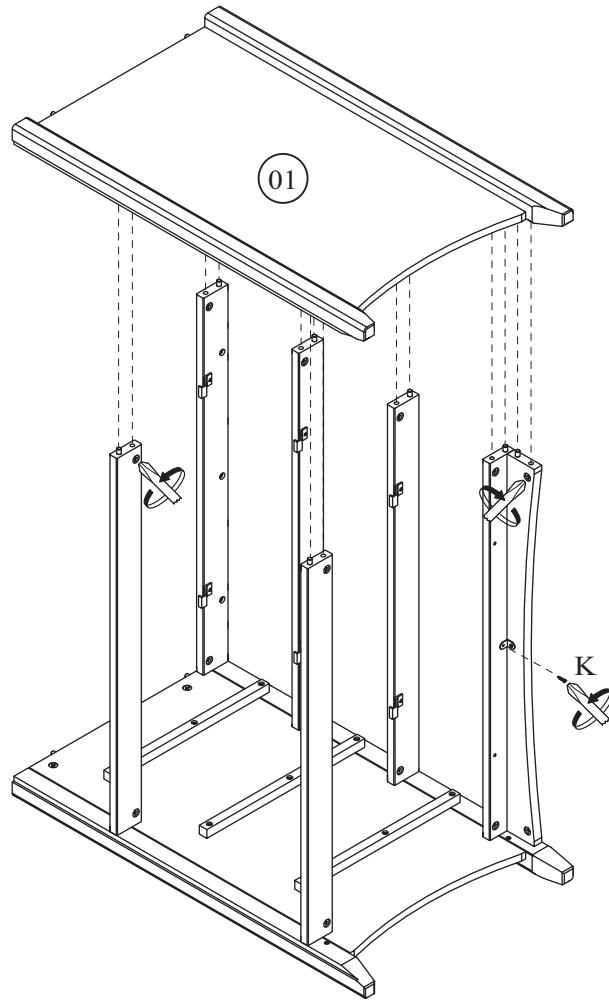

4

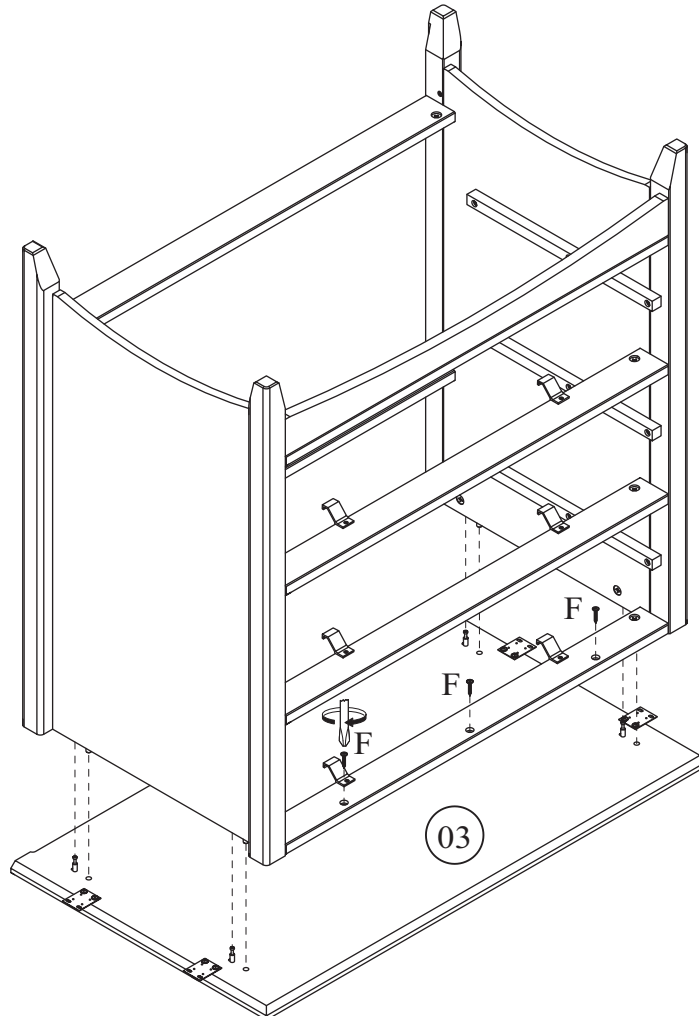



5

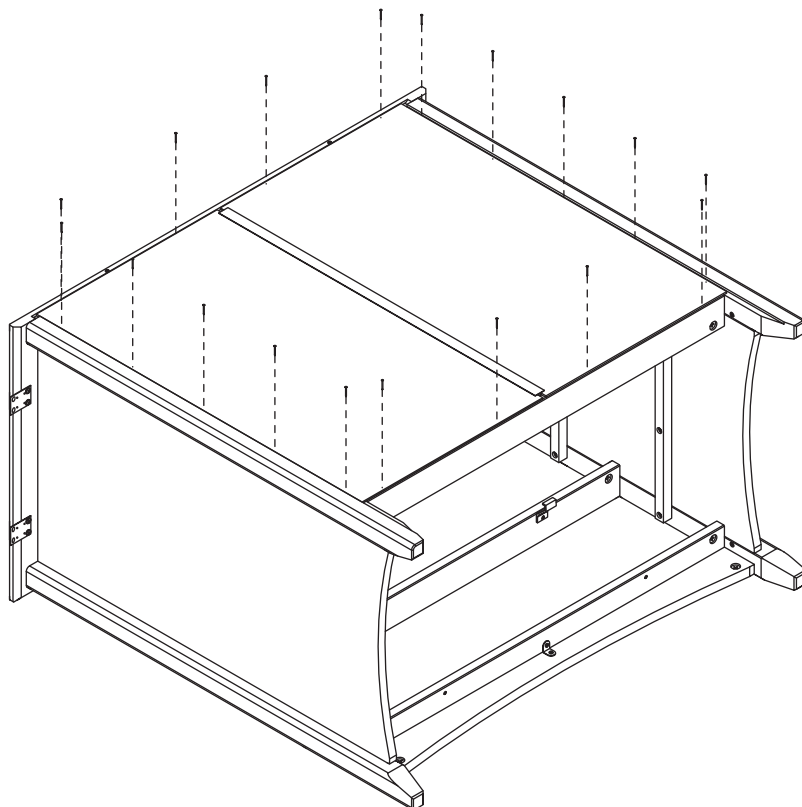
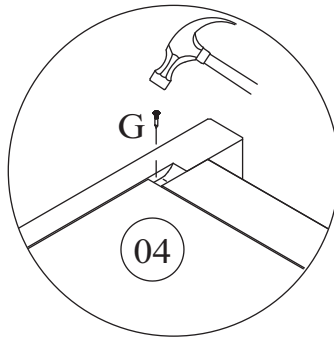
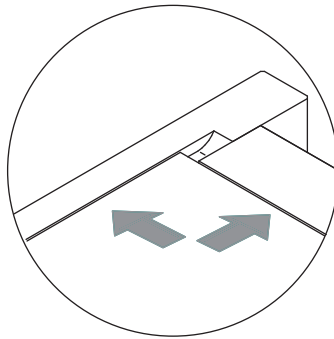
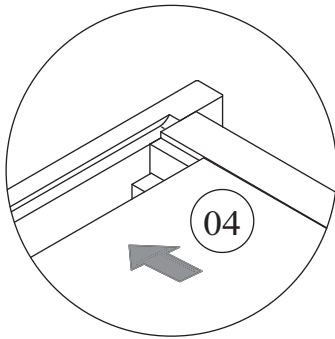
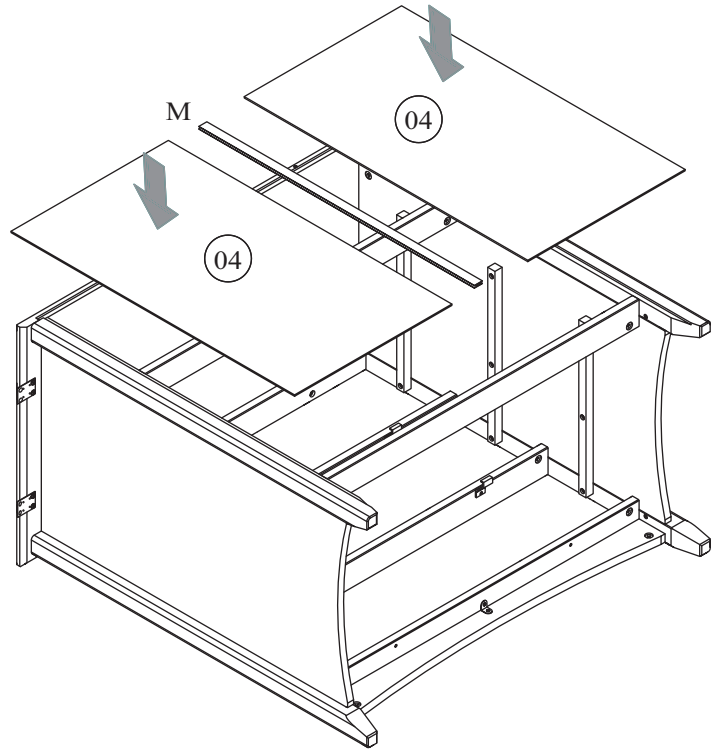
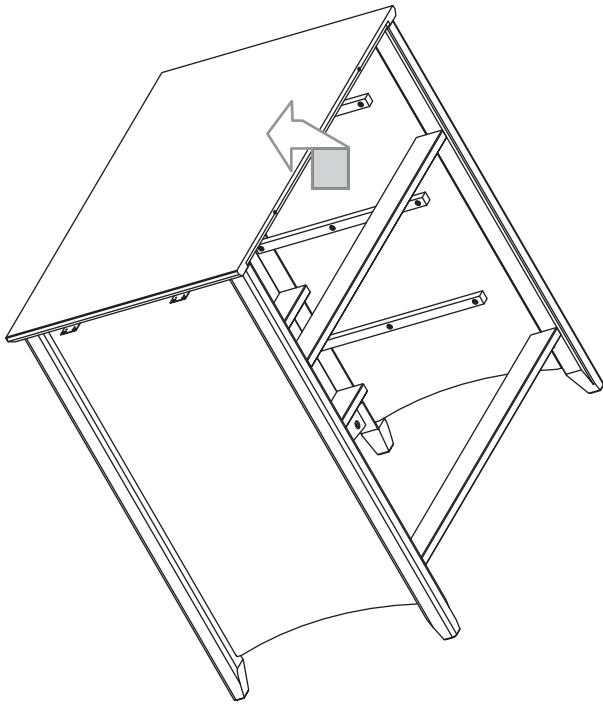



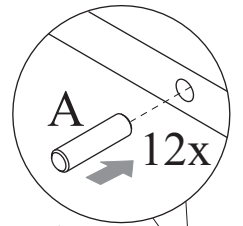
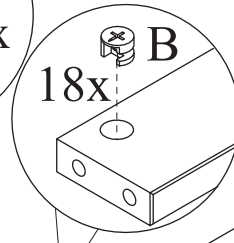
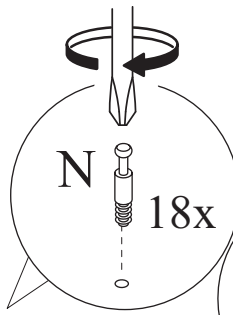
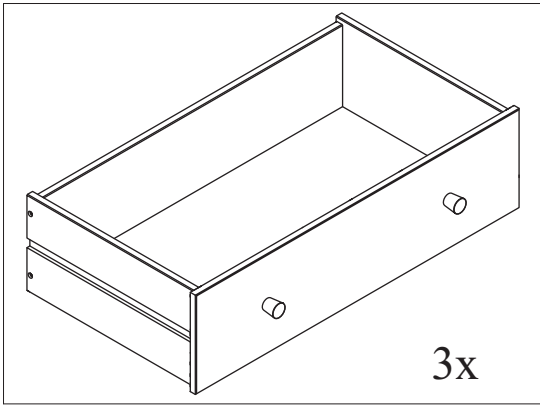

6

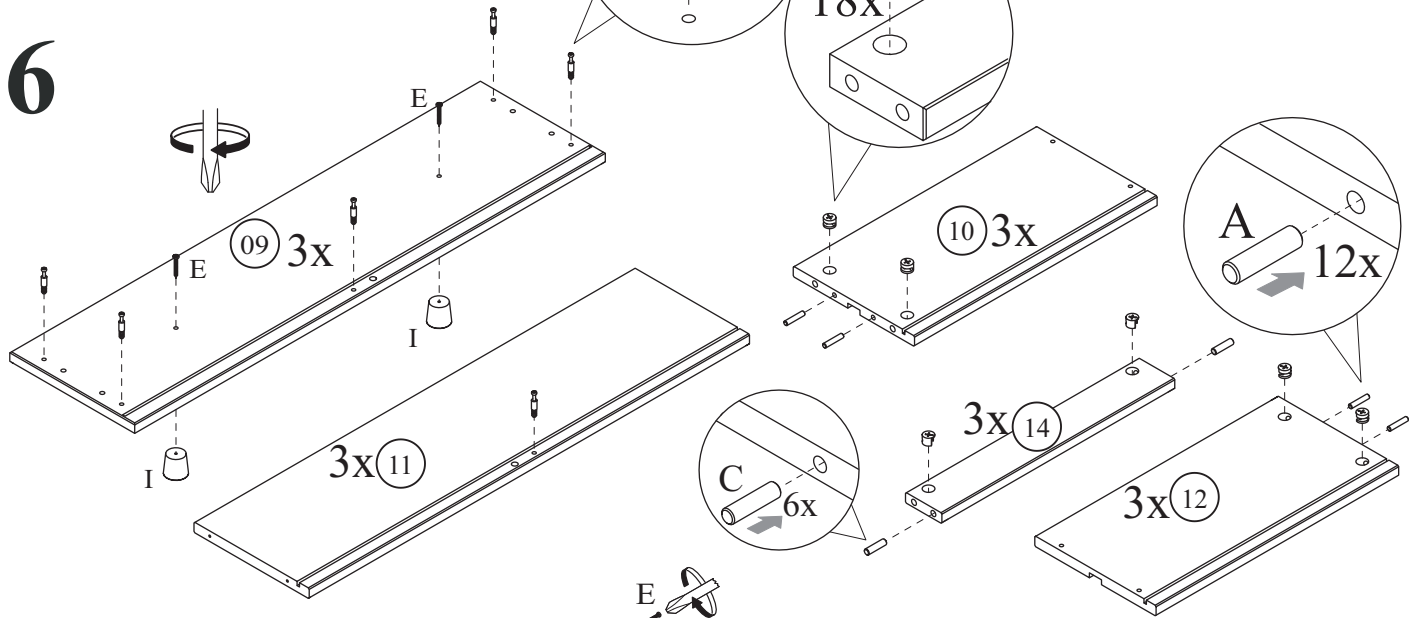

7

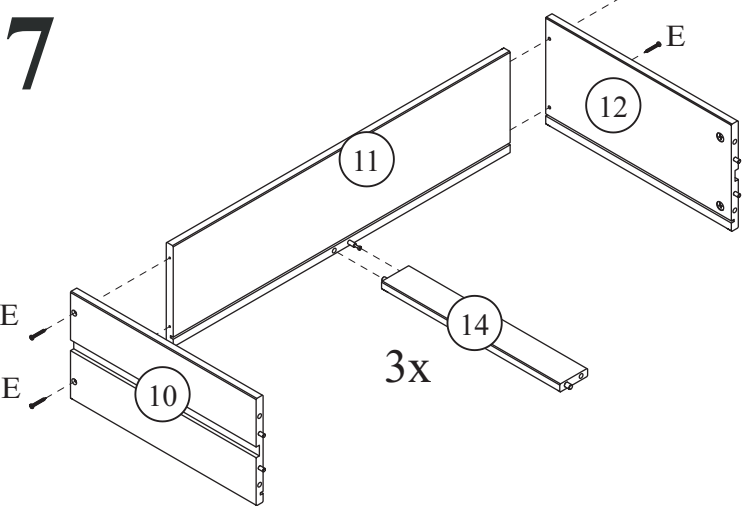

8

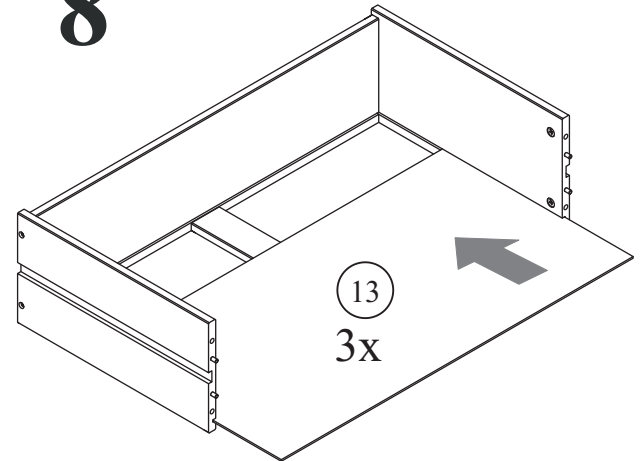

9

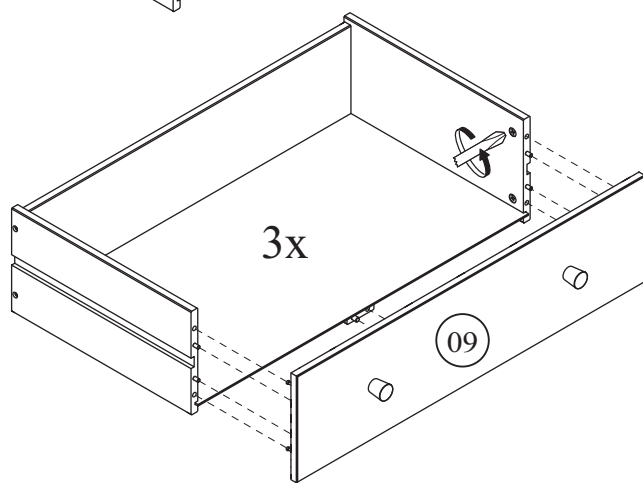

# 10

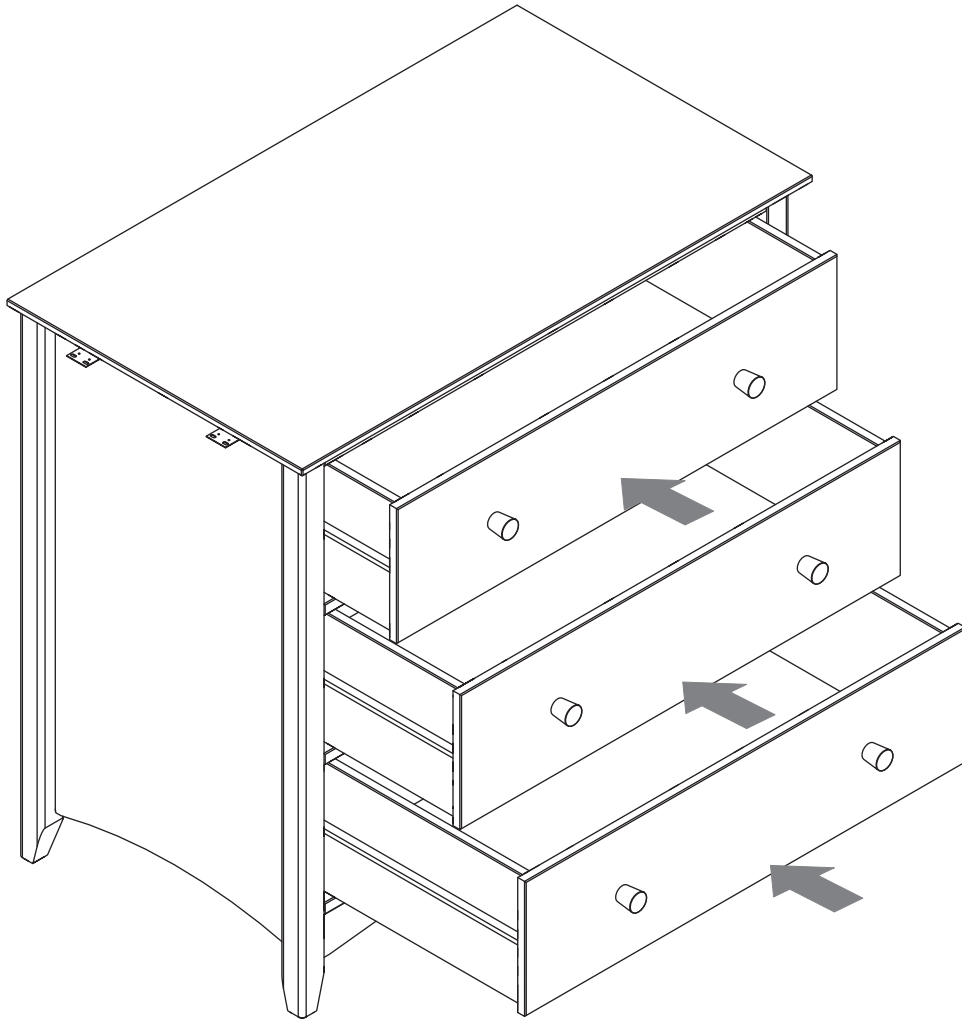

# 11

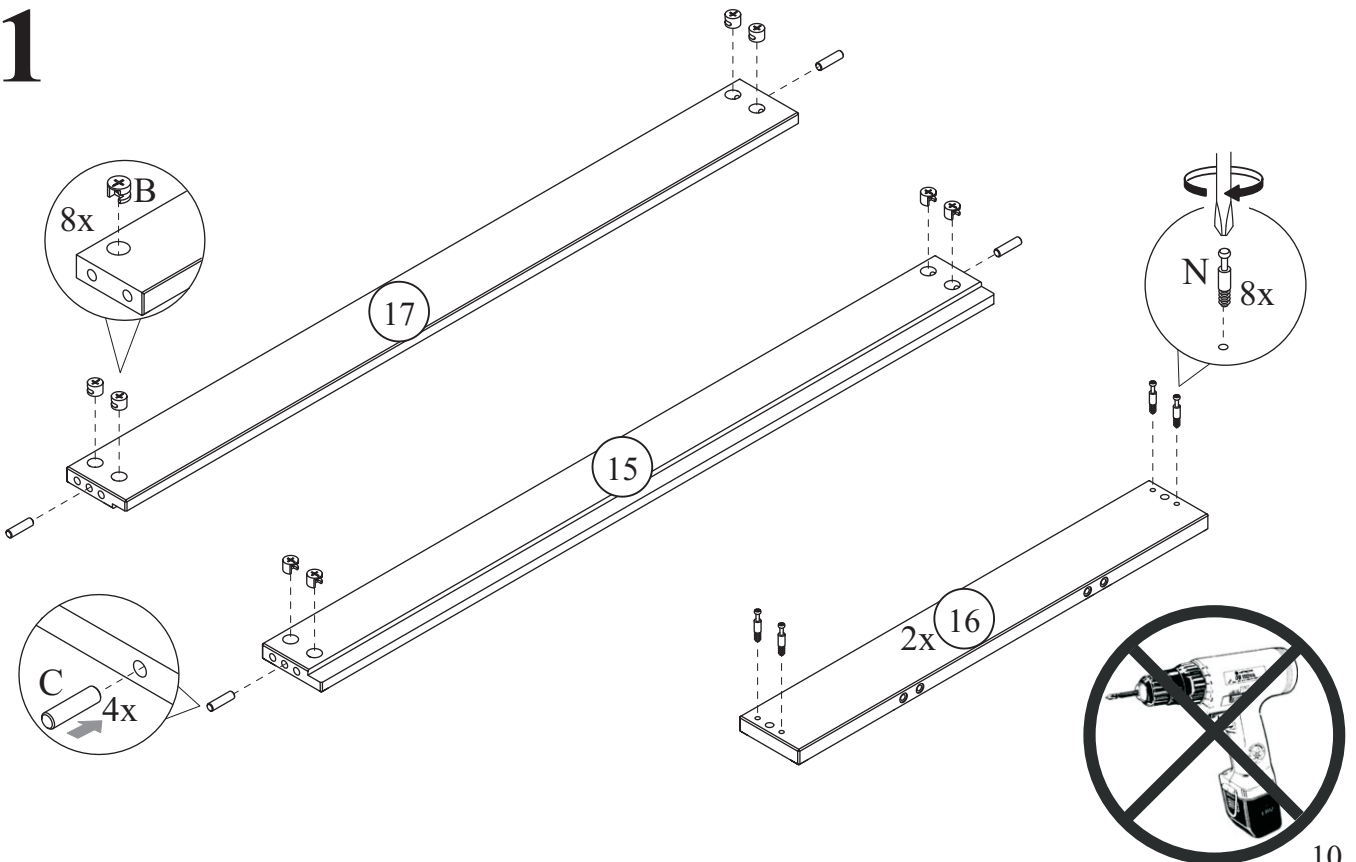

# 12

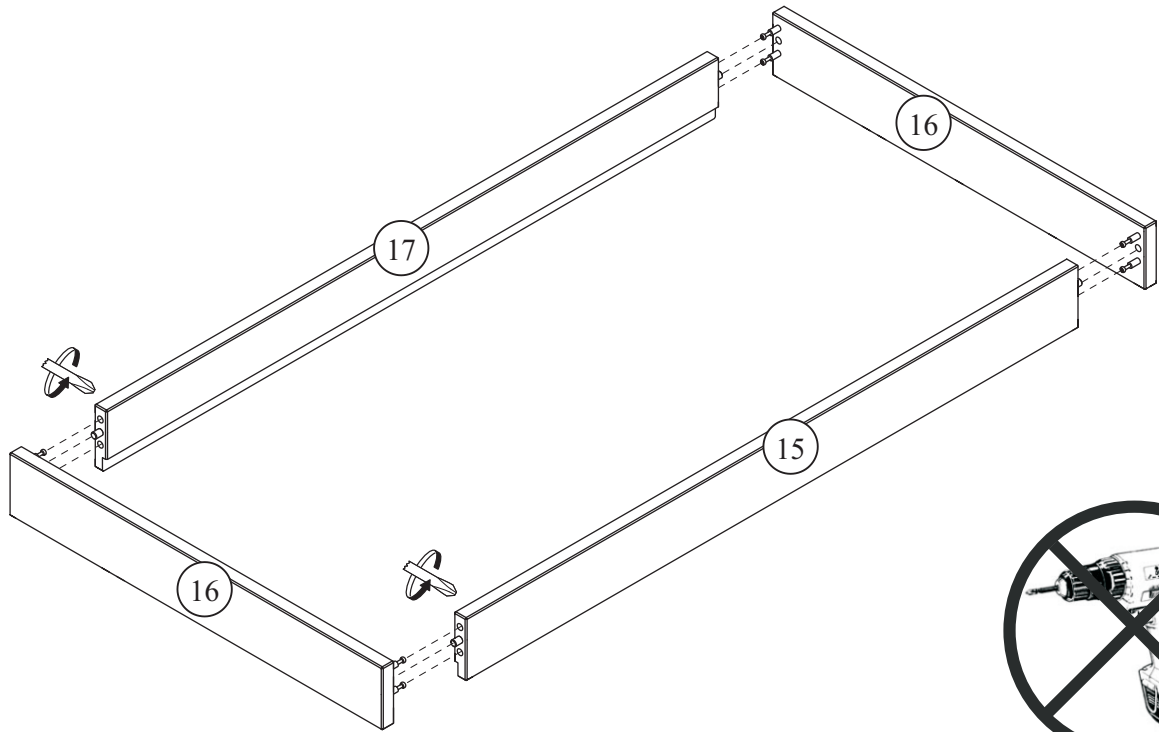

# 13

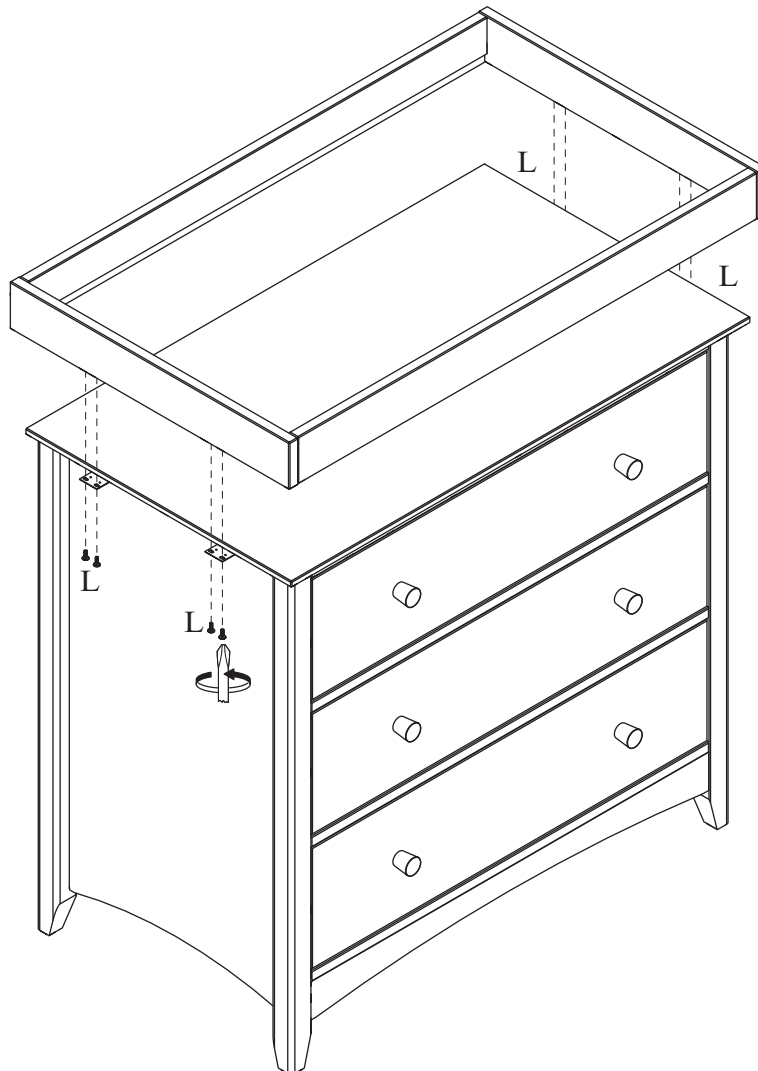

14

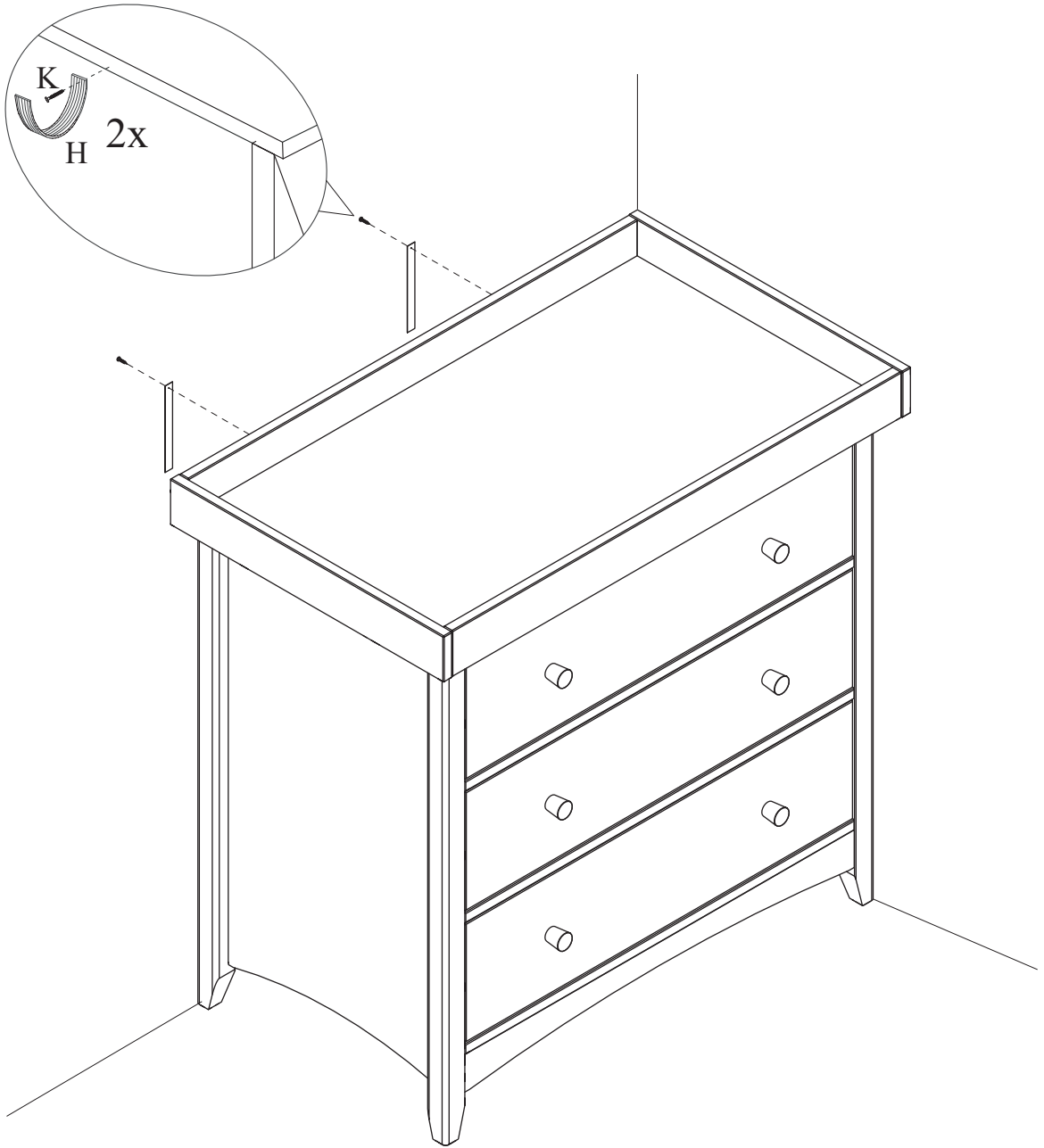

# 15

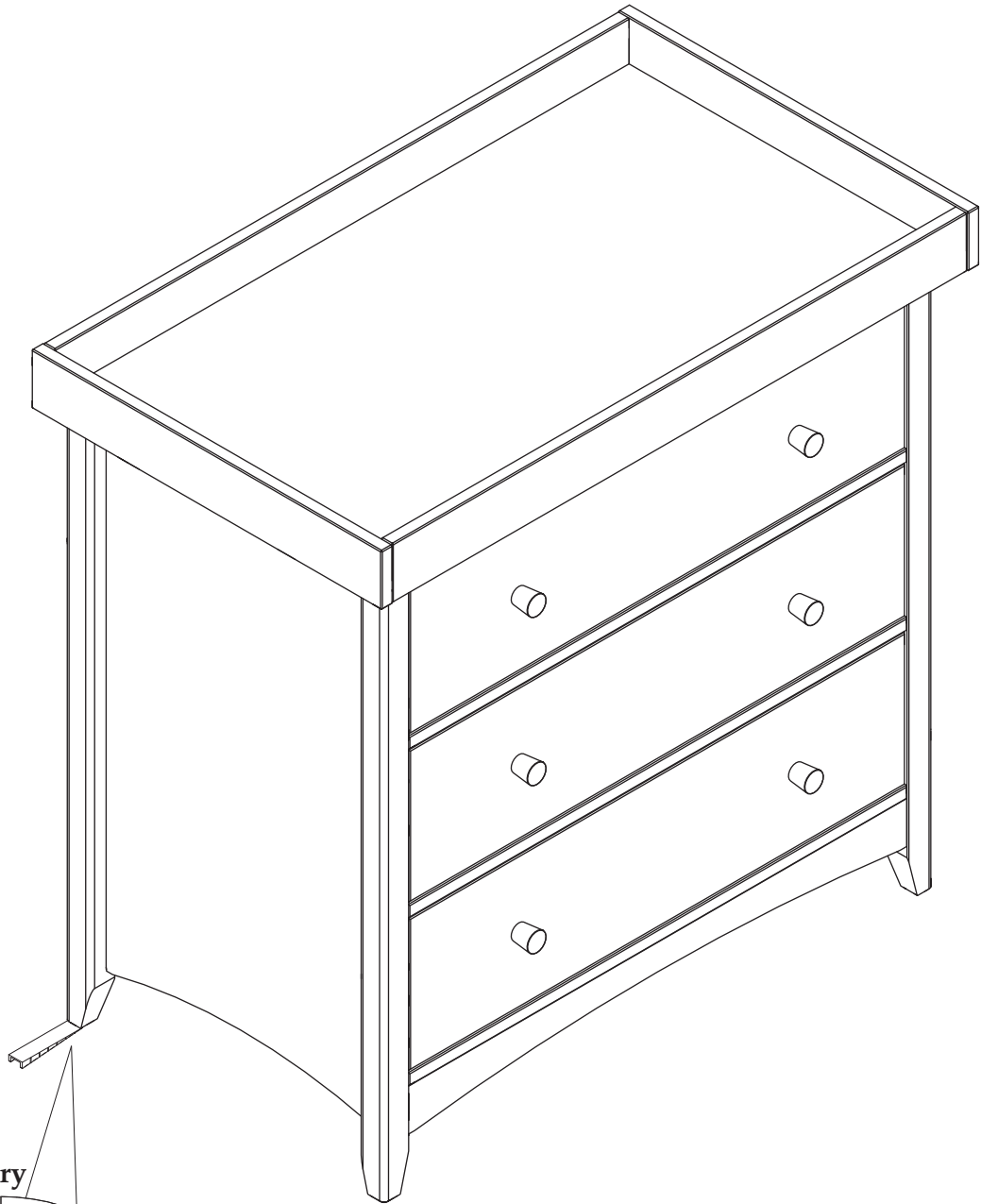

Use as necessary

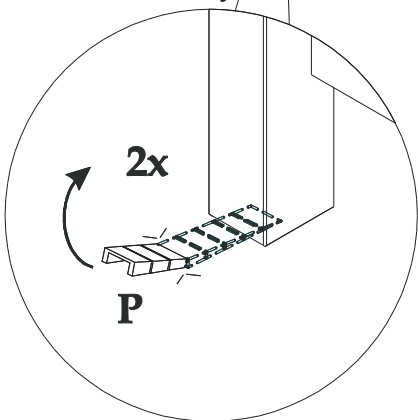

## **ADDITIONAL SAFETY INFORMATION**

**WARNING: In order to prevent overturning the wall attachment must be used with this product.**

In the interest of safety, particularly where small children are concerned, we advise securing your furniture to the wall to prevent the product tipping forward when loaded.

This product is heavy and could cause serious or fatal injury if not used or moved correctly.

The screw included in the fitting pack is only intended for fixing the safety strap to the piece of furniture.

Hardware to attach the strap/s to the wall are NOT INCLUDED. Use fixing devices suitable for the walls in your home (not included). If you are unsure what type of fixings to use, please seek further advice from your local DIY store.

## **GENERAL CARE & MAINTENANCE**

We advise that when cleaning the product that a damp cloth is used.

Avoid the use of all household cleaners and abrasive.

Never push or drag the furniture.

Never attempt to move the furniture when fully loaded.

We advise that periodically all fixings are re-tightened.